

Table 1-2. 9010A Specifications (cont)

9010A OPERATOR-ACCESSIBLE MEMORY

- Tape-Transferable Memory** Approximately 12k bytes for storage of UUT memory map information, Setup parameters, and programs. Contents may be transferred to and from cassette tape or transferred to and from a remote device via the RS-232 Interface Option.
- Registers** Sixteen 32-bit registers.

GENERAL

- Power Requirements** 100, 120, 220 or 240V ac $\pm 10\%$
50 or 60 Hz $\pm 5\%$
40 Watts maximum
- Size** 11.7x38.7x31.1cm. (HXWXL) (4.6x15.25x12.25in.) See Figure 1-2.
- Weight** 5 kg. (11 lb.)

Environmental

STORAGE TEMPERATURE

- Without Cassette Tape -40 to +70°C (RH <95%)
- With Cassette Tape +4 to 50°C (10% to 90% RH)

OPERATING TEMPERATURE

- Without Cassette Tape 0 to 25°C (RH <95%)
25 to 40°C (RH <75%)
40 to 50°C (RH <45%)
- With Cassette Tape 10 to 25°C (20% to 80% RH)
25 to 30°C (20% to 73% RH)
30 to 35°C (20% to 49% RH)
35 to 40°C (20% to 32% RH)

NOTE: All relative humidity (RH) conditions are non-condensing.

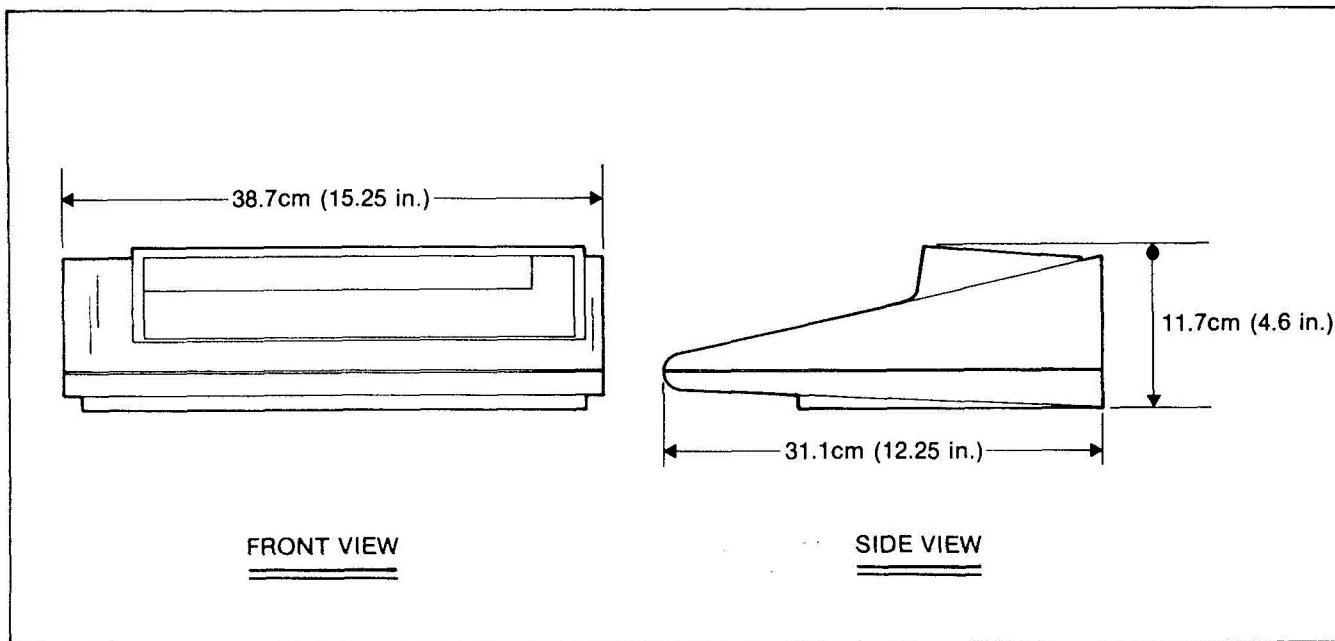

Figure 1-1. 9010A Outline Drawing

3-24. A data byte which indicates the logic level at the probe tip, or any invalid voltage condition, is sent by the probe logic to the appropriate port of the pod/probe PIA. The microprocessor reads the data byte applied to the pod/probe PIA port, after execution of a READ PROBE command, and determines the logic state at the probe tip (high, low, or invalid). The microprocessor then writes the appropriate message to the display/keyboard assembly for display to the operator.

3-25. Signature Generator/Event Counter Function

3-26. The signature generator receives the signal data read by the probe and, in conjunction with the SYNC pulse from the pod, applies these signals to the data and clock inputs of the signature shift register. As a result, the shift register generates a signature unique to the incoming probe signal. The event counter maintains a running total of high-to-invalid transitions (events) read by the probe.

3-27. Pressing the READ PROBE key causes the microprocessor to address (by means of the I/O selector) the signature generator and event counter circuit and reads their contents. The microprocessor then writes the current contents to a designated portion of RAM (register 0). With the signature and event count stored in RAM, the microprocessor resets the signature generator and event counter circuit permitting the next read probe operation to accumulate and yield new probe data. If the read probe operation was performed in the immediate mode, the microprocessor also sends new probe-tip state data, probe signature, and event count data to the Keyboard/Display Assembly for display to the operator.

3-28. Magnetic Tape Controller Function

3-29. The Magnetic Tape Controller controls the magnetic tape unit in response to commands from the microprocessor. The Magnetic Tape Controller contains a peripheral microcomputer which, under internal software control, performs the following functions:

- Reads to or writes from the tape.
- Controls tape direction and speed.
- Rewinds tape.
- Positions tape at load point.
- Formats write words.
- Decodes read words.
- Detects end of tape.
- Detects cassette present/not present.
- Detects write-protected cassette.

- Detects synchronization errors.
- Reports magnetic tape controller status to the main microprocessor.

3-30. RS-232 Interface Function (Option -001)

3-31. The RS-232 Interface provides an EIA RS-232-C compatible bidirectional interface to the troubleshooter with selectable baud rates of 110, 150, 300, 600, 1200, 4800, and 9600. The interface is isolated from the troubleshooter and meets all RS-232 requirements for bidirectional movement of serial data. The RS-232 Interface provides communications to and from other 9000 series troubleshooters or other RS-232 compatible devices. Refer to Section 6 for the description of the RS-232 Interface.

3-32. DETAILED BLOCK DIAGRAM DESCRIPTION

3-33. Introduction

3-34. The following paragraphs describe operation of the troubleshooter at a detailed block diagram level. Each description includes a block diagram which can be related to the schematic diagrams contained in Section 8.

NOTE

Memory and I/O devices are controlled by addresses and, in some cases, by data. Table 4-13 lists controlling addresses and data.

3-35. Control Section

3-36. The control section of the troubleshooter, shown in block diagram Figure 3-3, contains the clock, the microprocessor, RAM, ROM, RFSH/RAM control, memory page selector, RAM address 2:1 multiplexer, power-on reset circuit and watchdog timer, and an I/O selector. The control section operates as a small computer system to initiate and control, by means of software contained in ROM, all troubleshooter and interface pod functions.

3-37. CLOCK CIRCUIT

3-38. The clock circuit, made up of G1, U34 and U30, provides timing control for the troubleshooter. The clock circuit contains a 6.5 MHz oscillator, the output of which is divided by two to produce a 3.25 MHz output. The 3.25 MHz is buffered and fed to the microprocessor, the RFSH/RAM control circuit, and flip-flop U32. (Flip-flop U32 produces a clock pulse to drive the pod/probe PIA each time an I/O operation takes place. Refer also to the pod/probe PIA description.)

3-39. MEMORY PAGE SELECTOR

3-40. When enabled by the logic signal RFSH•MREQ the memory page selector, U62, produces an enable signal to an addressed memory device while inhibiting all other memories. The memory page selector, a ROM, decodes

gates the high byte of signature data onto the data bus; the $\overline{I/O3}$ signal gates the low byte.

3-105. The event counter U59 produces a seven-bit count (0-127 with wrap-around) of logic high-to-invalid transitions appearing at the probe tip. The input to the event counter is provided by the SIG Data signal from the high level detector of the probe logic. The event buffer, U60, gates the seven-bit event count plus the one-bit fuse-blown (\overline{FB}) indication onto the data bus in response to the $\overline{I/O0}$ signal from the I/O selector as commanded by the microprocessor.

3-106. The microprocessor resets both the signature generator and the event counter by means of the $\overline{I/O1}$ output of the I/O selector. Reset occurs at the beginning of all read probe operations.

3-107. Magnetic Tape Controller

3-108. INTRODUCTION

3-109. The Magnetic Tape Controller provides control of the magnetic tape unit in response to commands from the microprocessor. The Magnetic Tape Controller contains a peripheral microcomputer which, under internal software control, performs the following functions:

- Reads to or writes from the tape.
- Controls tape direction and speed.
- Rewinds tape.
- Positions tape at load point.
- Formats write words.
- Decodes read words.
- Detects end of tape.
- Detects cassette present/not present.
- Detects write-protected cassette.
- Detect synchronization errors.
- Reports tape subsystem status to the microprocessor.

NOTE

Refer to Table 4-13 for a list of addressing protocol for the magnetic tape controller.

3-110. Selection (addressing) of the Magnetic Tape Controller by the microprocessor is done by means of the $\overline{I/O5}$ output of the I/O selector described earlier in this

section. In addition, address line A0 provides the controller with two addresses. When the microprocessor writes A0 low, the information placed on the data bus is for a read data or write data operation, as determined by the \overline{RD} or \overline{WR} lines. However, when A0 is written high, a write operation issues a command to the peripheral microcomputer to place controller status on the data bus. The peripheral microcomputer also receives the system \overline{RES} signal generated by the power-on reset and watchdog timer circuits. Refer to Figure 3-11 for a block diagram of the magnetic tape controller.

3-111. TAPE DRIVE MOTOR CONTROL

3-112. A speed-regulated reel-drive motor moves the magnetic tape over the read/write head. To operate the motor in the forward direction, the peripheral microcomputer writes an output to the Forward line (and also an output to the \overline{E} line to enable all controller functions). The Forward signal operates the switch formed by U4B to connect the positive side of the tape drive motor to the +5 volt supply. As a result, motor current flows through U4B, through the motor, and out through back-EMF regulator, U6. The back-EMF regulator senses the voltage across the motor, which is proportional to motor speed, and provides the feedback necessary to maintain a constant motor speed. Potentiometer R14 provides a means of setting motor speed.

3-113. To operate the motor in the rewind direction, the peripheral microcomputer writes an output to the REWD line, and also to the \overline{E} line. The REWD signal turns on solenoid driver, U4A, to actuate the rewind solenoid, closes the switch formed by U4C, and closes the switch formed by U4D and Q1. As a result, motor current flows from the +5 volt supply through U4C, bypasses U6, flows through the motor and through Q1 to the ground. Since regulator U6 is bypassed, motor rewind speed is uncontrolled and is the maximum provided by five volts.

3-114. WRITE CONTROL

3-115. To avoid any possible errors which might result from tape jitter or speed variation, a method of ratio encoding is used to write all data on the tape. Figure 3-12 illustrates the method of ratio encoding employed by the magnetic tape controller. Any data bit is either 2/3 bit time high or low, with the other 1/3 bit time of the opposite polarity. A one bit begins low, and after 1/3 of the bit time makes a transition to high for the remaining 2/3 of the bit time. A zero bit also begins low, but stays low for 2/3 of the bit time, after which it makes a transition to high for the remaining 1/3 of the bit time. Under this coding scheme, the first 1/3 of a bit is always low, and the last 1/3 of a bit is always high. An extra 1/3 low provides a stop mark, and an inter-word high of 1-2/3 bit times is written for synchronization purposes. A high for ten word lengths indicates end-of-file.

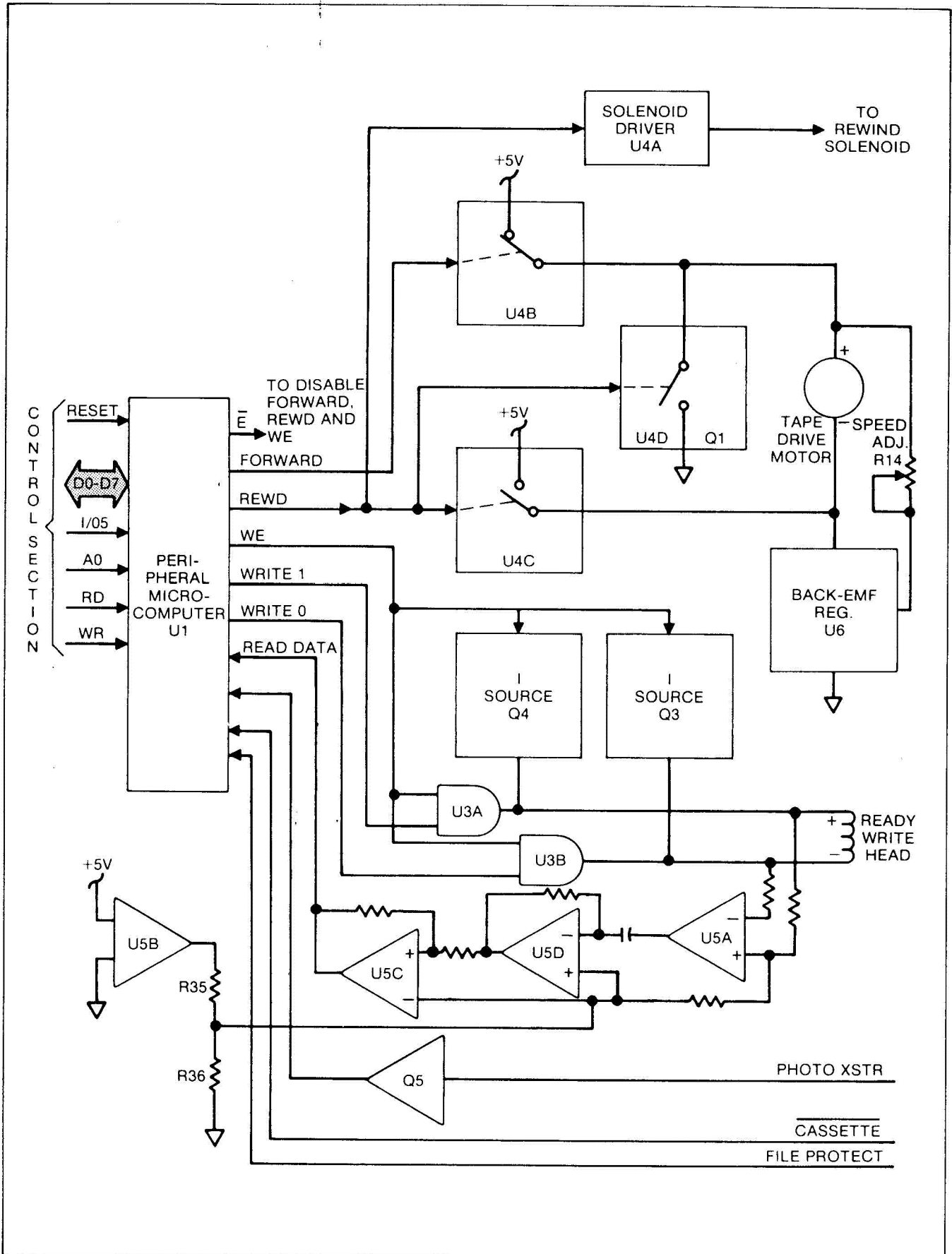

Figure 3-11. Magnetic Tape Controller

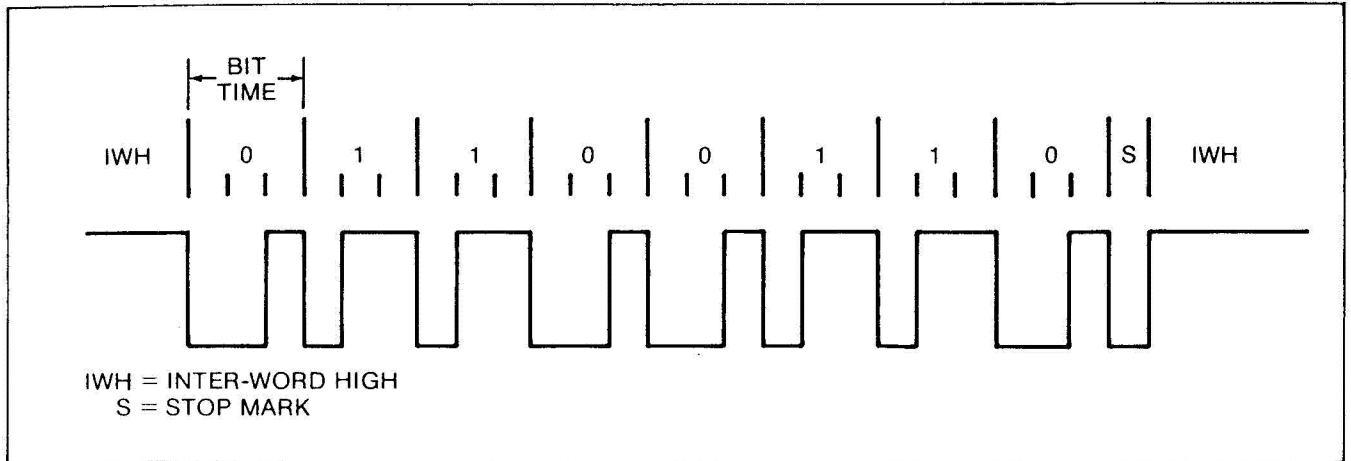

Figure 3-12. Tape Data Ratio Coding

3-116. To write to the tape, the peripheral microcomputer writes a WE (write enable) signal to current sources Q3 and Q4, and to current sinks U3A and U3B. The WE signal turns on the current sources and enables the current sinks. To write a high to the tape, the peripheral microcomputer writes to the WRITE 1 line to turn on current sink, U3A. When turned on, U3A directly sinks the current supplied by Q4, and also sinks the current supplied Q3 after passing through the read/write head in a negative-to-positive direction.

3-117. The read/write head records the transition as a flux change on the tape. To write a low to the tape, the peripheral microcomputer writes to the WRITE 0 line to turn on current sink, U3B. When turned on, U3B directly sinks the current supplied by Q3, and also sinks the current supplied by Q4 after passing through the read/write head in a positive-to-negative direction (opposite to the direction when writing a high level). The read/write head records the transition as a flux change on the tape, but of the opposite polarity of that recorded for the high portion of a data bit.

3-118. PLAYBACK AMPLIFIER

3-119. All signals appearing across the read/write head, including those written by the peripheral microcomputer, are applied to the input of the playback amplifier made up of U5A, U5B, U5C, and U5D (shown in Figure 3-11). The purpose of U5B is to establish a reference voltage which is halfway between the upper and lower output limits of the other three stages. Since the output characteristics of U5B are similar to the other three stages, and R35 and R36 are

equal, applying +5 volts across the input of U5B produces a level equal to half its saturated output across R36.

3-120. Section U5A of the amplifier provides a gain of 200 and forms the first stage of the playback amplifier. The output of U5A is applied to differentiator stage U5D. CR8 and CR9 are provided to prevent this stage from going into saturation. The final stage is a center-crossing detector with a 25% (approx. $\pm 0.4V$) hysteresis. The three stages combined are used to detect the points of flux reversal on the tape. The output of the playback amplifier connects via the Read Data line to an input of the peripheral microcomputer. The peripheral microcomputer continuously reads this input during a read operation and decodes the incoming data into logic highs and logic lows.

3-121. OTHER FUNCTIONS

3-122. The Magnetic Tape Controller includes three other functions required for proper tape handling, each of which is reported to the peripheral microcomputer. An LED and phototransistor mounted on the tape path provide an indication of end-of-tape when the clear section of tape allows the passage of LED output to reach the phototransistor. Transistor Q5 amplifies the phototransistor output for application to the peripheral microcomputer. In addition, a low $\overline{\text{Cassette}}$ signal indicates the presence of a cassette in the tape drive to the peripheral microcomputer; and a high File Protect signal indicates a write protected (the tab broken out) cassette. Both the File Protect and $\overline{\text{Cassette}}$ signals are produced by microswitches.

4-19. Probe Level Detection/Verification

4-20. Check for proper probe detection threshold levels follows:

1. Connect the probe of the 9010A across the output of a variable dc power supply and the input of a 3-1/2 digit multimeter so that the probe tip connects to the positive terminals and the ground lead connects to the negative terminals. Select an output of zero volts on the power supply.
2. Select free-run synchronization by pressing SYNC followed by F. Press RUN UUT.
3. Increase the power supply output from zero until the green probe lamp just goes out. The level on the multimeter should be 0.8 ± 0.2 volts.
4. Continue to adjust the power supply output until the red probe lamp just lights. The multimeter should read 2.4 ± 0.2 volts.
5. If these levels are not met, proceed to the paragraphs titled Checking the Probe Logic.
6. Disconnect probe tip from power supply.

4-21. Probe Pulsar Checks

1. Check for proper pulsar operation as follows:

1. Set free-run sync by pressing SYNC followed by F.
2. Select PULSE LOW and verify that the green light on the probe flashes.
3. Select PULSE HIGH and deselect PULSE LOW; verify that the red light on the probe flashes.
4. Select both HIGH and LOW and verify that both lights flash.

4-23. Magnetic Tape Check

4-24. Check for proper magnetic tape operation as follows:

1. Install a blank tape (not write protected) into the tape drive and close the lid.
2. Press WRITE TAPE and ENTER/YES. The tape drive should rewind, write, rewind, read, and rewind. The 9010A should display WRITE TAPE OK.

4-25. Pod Connector Checks

4-26. Check the pod connector as follows:

1. Connect a known good interface pod to the 9010A and place the UUT connector of the pod into its self-test connector.

2. Press BUS TEST and verify the message xxxx-POD SELF-TEST OK appears (where xxxx indicates the interface pod type).

4-27. Display/Keyboard Check

4-28. Check the display/keyboard assembly as follows:

1. Key-in the programs listed in Table 4-2 and then execute program 0. Note that the PRGMING and EXECUTING annunciators light.

2. The display should read all "8"s and the STOPPED annunciator should light.

3. Press CONT and the display reads all *. Press CONT and all decimal points are displayed. Press CONT.

4. The display reads KEY=. Press all keys except STOP, LOW or HIGH and verify the hexadecimal value is the same as shown in Figure 4-3. Press STOP to exit program.

4-29. CALIBRATION ADJUSTMENTS**4-30. Power Supply Adjustment**

4-31. Adjustment (R2), shown in Figure 4-4, is provided for the +5-volt supply and should be adjusted to obtain a level of +5.0 volts ± 10 mV at TP10. For proper power supply loading, all assemblies should be connected to the Main Assembly.

4-32. Magnetic Tape Speed Adjustment

4-33. Tape speed can be checked and, if necessary, adjusted by means of the following procedure. Gain access to the Magnetic Tape Controller by removing the seven 9010A cover-retaining screws, removing the cover and to expose the Magnetic Tape Controller Assembly.

1. Open the cassette access door of the tape drive and place a strobe disk (part no. 609578 for 60 Hz operation, and part no. 609560 for 50 Hz operation) on the left spindle.

2. Power the 9010A off then on.

3. Select the read test by momentarily jumpering pins 20 and 22 of U1 on the magnetic tape controller assembly.

4. Observe the strobe disk while adjusting R14 (shown in Figure 4-5). The disk strobe lines appear motionless when proper speed is achieved.

- An open switch causes a portion of the pattern to remain.

3. DISPLAY/KEYBOARD RESET

4-81. To reset the Display/Keyboard Assembly, momentarily jumper TP5 (ground) to TP4 (located on the Display Assembly) or, if the UUT is connected to a tester 9010A, perform WRITE @ 10081 = 00, followed by WRITE @ 10081 = 00.

4-82. DISPLAY KEYBOARD COMMUNICATION CHECKS

4-83. Communication between the microprocessor and the display/keyboard peripheral microcomputer may be checked by keying-in programs 6, 12, and 13 listed in Table 4-12 and executing program 6. The program verifies that the main microprocessor is able to communicate with the peripheral microcomputer by attempting to write data to the display and read data from the keyboard. In addition, proper operation of the status registers are verified and also the self-test commands are checked for proper operation.

4-84. Magnetic Tape Controller

4-85. The Magnetic Tape Controller contains resident test programs which provide testing of the controller and tape drive. These tests can be performed at any time without the need for a tester 9010A by removing the troubleshooter cover and inverting it to expose the Magnetic Tape Controller shown in Figure 4-5. Apply power to the troubleshooter and perform any or all of the following tests.

4-86. SELF TEST

4-87. Initiate self test by removing and reapplying power to the 9010A and then momentarily jumpering pins 20 (ground) and 21 (SLFTST) of microcomputer U1 on the Magnetic Tape Assembly. (Be sure to use a blank tape, or one that contains old data and is not write-protected.) The self test causes the controller to perform the following functions:

- Rewind the tape
- Write one thousand words of known data
- Rewind the tape
- Read and check the written data
- Stops upon the detection of any read error
- Repeats the entire sequence until reset by jumpering pins 20 and 4 of microcomputer U1

8. If the magnetic tape drive stops during the self test, a failure is indicated. Perform the read and write tests in order to isolate the fault. If the magnetic tape drive passes

the read and write tests, perform the checks presented under the heading Magnetic Tape Communications Checks.

4-89. MAGNETIC TAPE READ TEST

4-90. Initiate the read test by momentarily jumpering pins 20 and 22 (RDTST) of microcomputer U1. The read test causes the controller to perform the following functions:

- Rewind the tape
- Operate the tape drive in the read mode
- If a cassette is installed, rewinds at end-of-tape and repeats the read operation

4-91. During performance of the read test, make the following checks:

1. During the rewind portion of the read test, check for approximately +4.8V (solenoid voltage) at A4J2, pin 14; approximately +0.2V (+ motor voltage) at A4J2, pin 17; and approximately +4.8V (- motor voltage) at A4J2, pin 18. If any voltage is not correct, trace the signal from U1, pin 33, (REWD) through U2 and U4 to locate the fault. Also verify that the solenoid pulls in during rewind.

2. Using an oscilloscope, verify that U1, pin 27 (CLEAR LEADER) is high just as the tape starts forward and is still on clear leader, and then drops low. Also observe a low 20 ms pulse as the start-of-tape hole passes over the optical sensing path. If these signals do not occur, check Q5; verify that the LED conducts by measuring voltage drop across R38; and check that A4J2, pin 8 (PHOTO XSTR) drops low when on clear leader. If all active devices appear normal, check alignment of the optical path.

3. During forward read, the Motor (+) voltage (A4J2-17) should be at approximately +4.8V dc. If not, check the Forward signal from U1-32 through U2-A and transistor U4B. The Motor (-) (A4J2-18) should measure approx 2.5V dc. If not check U6 and its related components.

4. Using a tape with data already recorded and a storage type oscilloscope, verify the waveforms at U5A-1, U5D-14, U5C-8 and U5B-7 against those shown in Figure 4-10. Be sure to note the voltage levels. Be sure the Head(+) (A4J2-3) and Head(-) (A4J2-4) wires are connected. If the proper signals are not present, a faulty U5 or an open resistor is indicated. Be sure to check that the signal at U5B-8 is also present at U1-39.

5. Verify that U1-27 is logic low with a cassette installed and logic high when the tape lid is open.

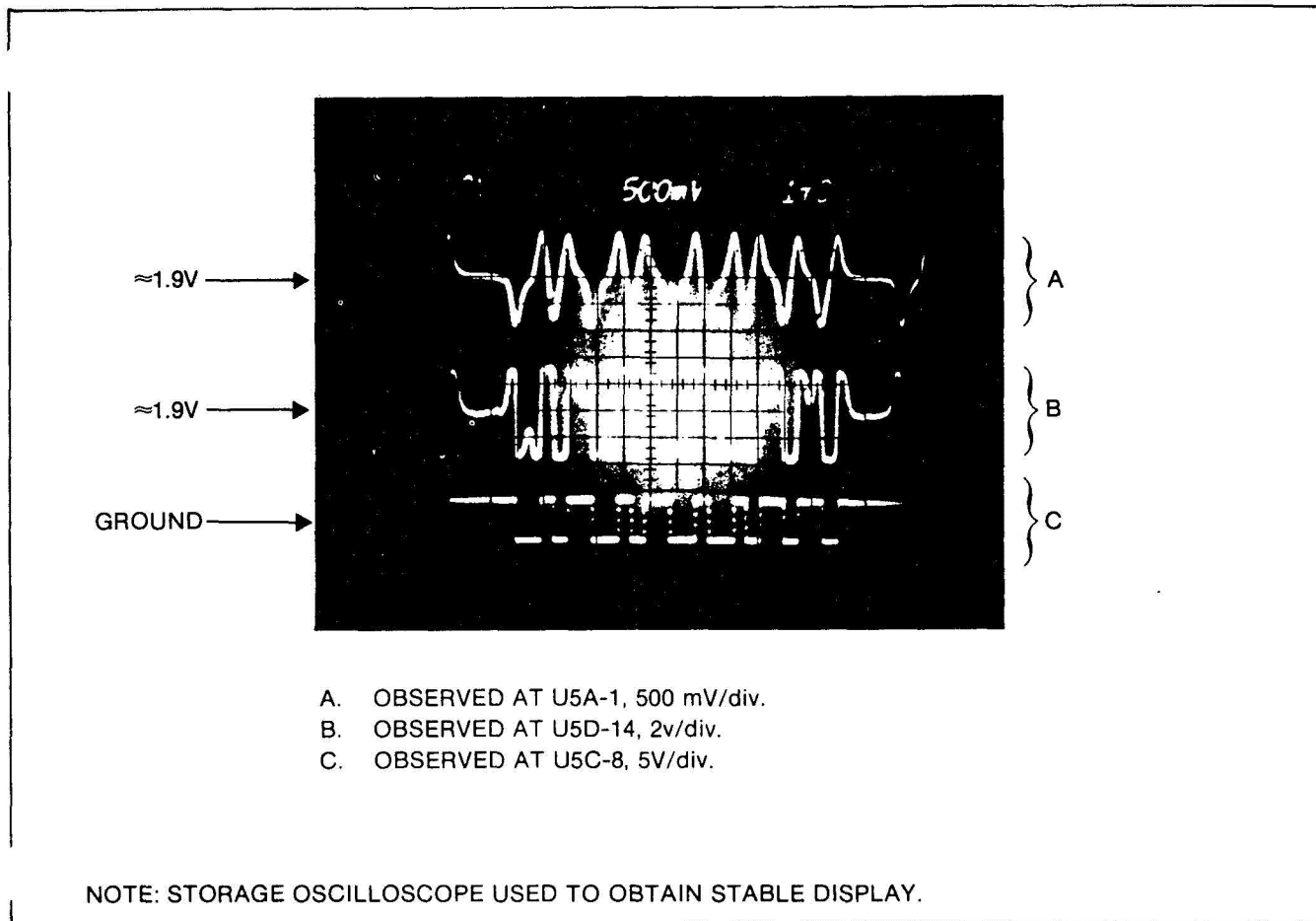

Figure 4-10. Read Test Waveforms

6. Verify that U1-38 is logic low with a cassette installed that has the file protect tab not removed, and logic high if the tab is removed.

4-92. MAGNETIC TAPE WRITE TEST

4-93. Initiate the write test by momentarily jumpering pins 20 (ground) and 23 (WTTST) of microcomputer U1. The write test causes the controller to perform the following functions:

- Rewind the tape.
- Operate the tape drive in the forward direction and write the hexadecimal word CA at all locations on the tape.
- Rewinds at end-of-tape and repeats the write operation.

4-94. During performance of the write test, verify that the Head signal at A4J2-3 and the Head-signal at A4J2-4 appear as shown in Figure 4-11. If the signals are not as shown, check gates U3-A, B, and D; transistors Q2, Q3, and Q4; and associated resistors.

4-30

NOTE

If the read and write test fail to isolate and correct a fault that causes failure of self test, it is possible that the controller passes self test but does not communicate properly with the main microprocessor.

4-95. MAGNETIC TAPE COMMUNICATION CHECKS

4-96. Communications between the microprocessor, via the address and data bus, can be checked by means of a tester 9010A connected as described for Bus/RAM/ROM Checks. Using the tester 9010A, check communication by performing the following operations:

1. Disable the watchdog timer U31 by jumpering the C16 side of or R14 (located on the main assembly) to TP12 (ground).
2. Remove any tape cassette and leave the door open.

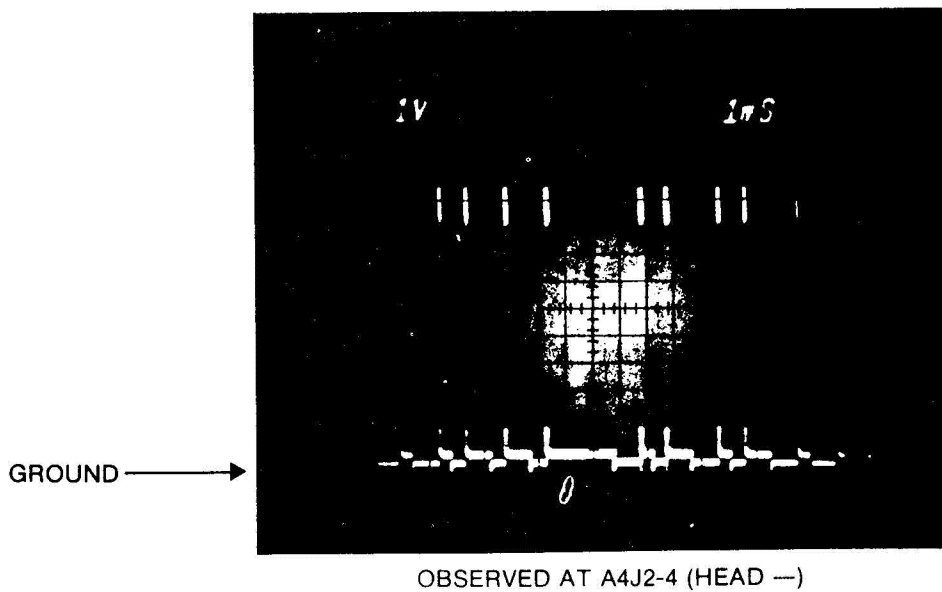
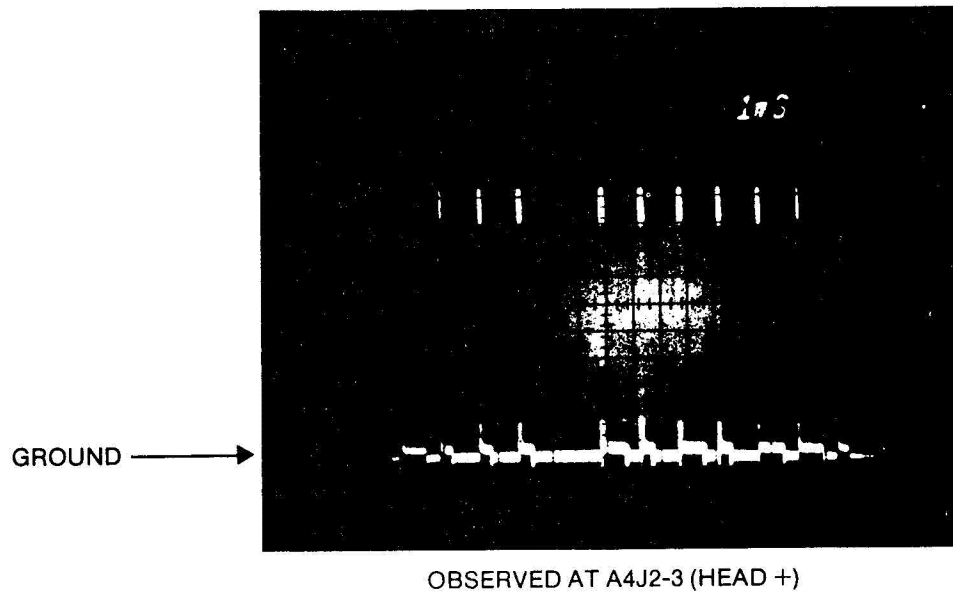

NOTE: STORAGE OSCILLOSCOPE USED TO OBTAIN STABLE DISPLAY.

Figure 4-11. Write Test Waveform

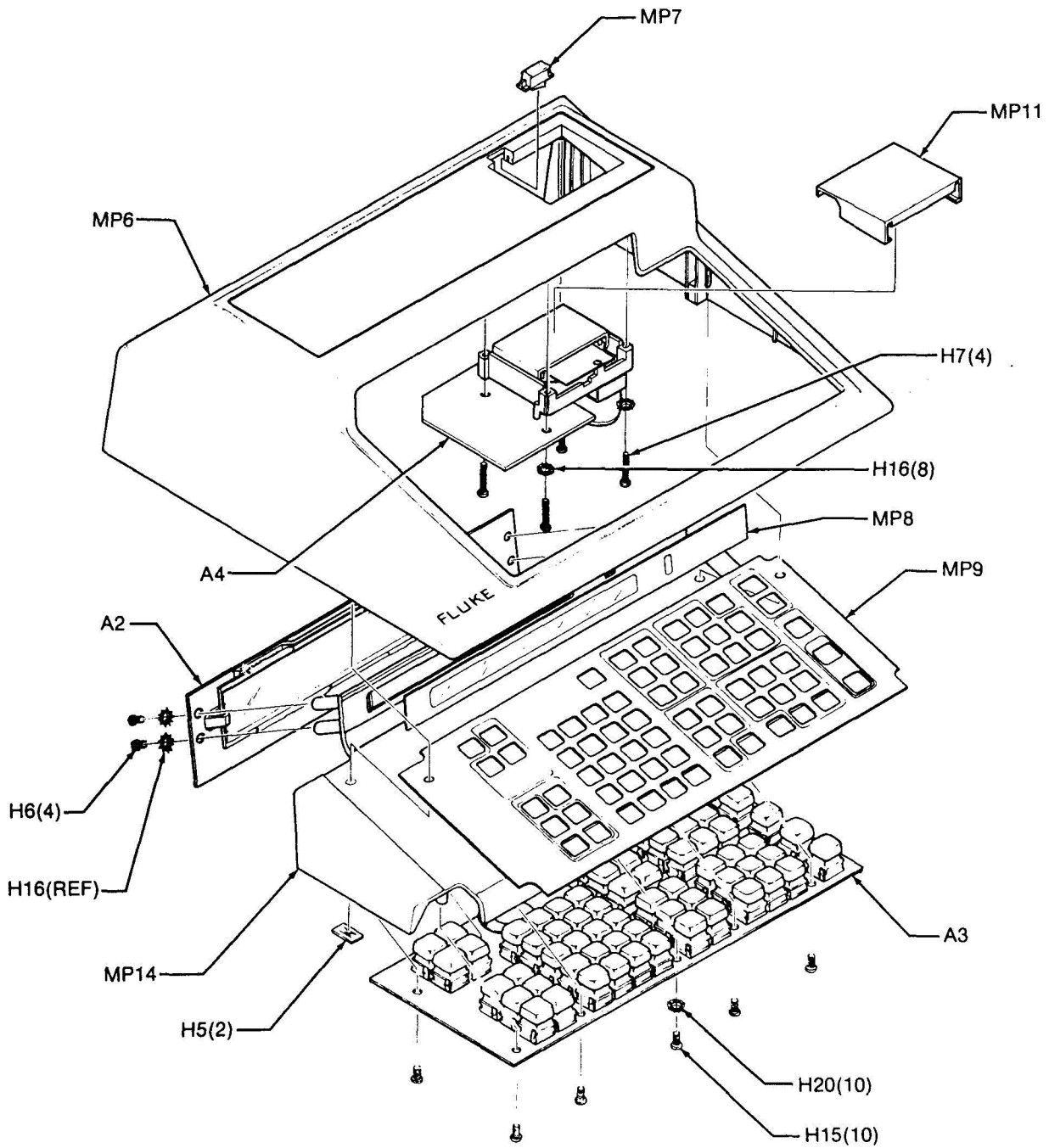

KEYBOARD SECTION

9010A-5031
3 of 3

Figure 5-1. Final Assembly (cont)

Table 5-5. A4 Magnetic Tape PCB Assembly

REF DES	DESCRIPTION	FLUKE STOCK NO.	MFG SPLY CODE	MFG PART NO.	TOT QTY	REC QTY	NO TE
A4⊙	MAGNETIC TAPE PCB ASSEMBLY FIGURE 5-5 (9010A-4034T)	579441	89536	579441	REF		
C2	CAP, CER, 20 PF +/-10%, 500V	106369	56289	561CT2HBA102AE200K	1		
C3	CAP, CER, 0.22 UF +/-20%, 50V	519157	51406	RPE111Z5U224M50V	4		
C4	CAP, ELECT, 10 UF -10/+50%, 25V	170266	73445	ET100X025A2	3		
C5	CAP, CER, 0.22 UF +/-20%, 50V	519157	51406	RPE111Z5U224M50V	REF		
C6	CAP, ELECT, 10 UF -10/+50%, 25V	170266	73445	ET100X025A2	REF		
C7	CAP, ELECT, 4700 UF -10/+50%, 5V	572511	89536	572511	1		
C8	CAP, CER, 180 PF +/-10%, 1000V	105890	56289	C023B102E181M	1		
C9	CAP, CER, 0.22 UF +/-20%, 50V	519157	51406	RPE111Z5U224M50V	REF		
C10	CAP, TA, 4.7 UF +/-20%, 25V	161943	56289	196D475X0025KA1	2		
C11	CAP, TA, 4.7 UF +/-20%, 25V	161943	56289	196D475X0025KA1	REF		
C12	CAP, CER, 39 PF +/-5%, 1000V	417410	72982	858-000-R2G0-390J	1		
C13	CAP, CER, 0.01 UF +/-20%, 100V	407361	72982	8121-A100-W5R-103M	1		
C14	CAP, ELECT, 10 UF -10/+50%, 25V	170266	73445	ET100X025A2	REF		
C15	CAP, CER, 0.22 UF +/-20%, 50V	519157	51406	RPE111Z5U224M50V	REF		
C16	CAP, CER, 0.1 UF, GMV, 10V	368647	71590	UK10-104	1		
CR1-7	DIODE, SI, HI-SPEED SWITCHING	203323	04713	1N4448	7	2	
CR8	DIODE, SI, MULTI-PELLET	375485	09214	MPD300	2	1	
CR9	DIODE, SI, MULTI-PELLET	375485	09214	MPD300	REF		
H1	SCREW, PHP, 2-32 X 1/4	602128	89536	602128	3		
J1	CONNECTOR BODY	530154	89536	530154	1		
J2	CONNECTOR, POST	267500	00779	86144-2	21		
MP1	CONNECTOR COVER (W/J1)	530162	89536	530162	1		
MP2	RECORDER, MAGNETIC TAPE	574459	89536	574459	1		
Q1	TRANSISTOR, SI, NPN	330803	04713	MPS6560	1	1	
Q2-5	TRANSISTOR, SI, PNP	195974	04713	2N3906	4	1	
R1	RES, DEP. CAR, 10 +/-5%, 1/4W	572941	80031	CR251-4-5P10E	1		
R2	RES, DEP. CAR, 10K +/-5%, 1/4W	573394	80031	CR251-4-5P10K	5		
R3	RES, DEP. CAR, 10K +/-5%, 1/4W	573394	80031	CR251-4-5P10K	REF		
R4	RES, DEP. CAR, 110 +/-5%, 1/4W	442285	80031	CR251-4-5P110E	1		
R5	RES, DEP. CAR, 100K +/-5%, 1/4W	573584	80031	CR251-4-5P100K	9		
R6	RES, COMP, 1.2 +/-5%, 1/2W	218701	01121	EB1R25	1		
R7	RES, DEP. CAR, 360 +/-5%, 1/4W	573097	80031	CR251-4-5P360E	1		
R8	RES, DEP. CAR, 100K +/-5%, 1/4W	573584	80031	CR251-4-5P100K	REF		
R9	RES, DEP. CAR, 200 +/-5%, 1/4W	573055	80031	CR251-4-5P200E	4		
R10	RES, DEP. CAR, 10K +/-5%, 1/4W	573394	80031	CR251-4-5P10K	REF		
R11	RES, DEP. CAR, 200 +/-5%, 1/4W	573055	80031	CR251-4-5P200E	REF		
R12	RES, DEP. CAR, 100K +/-5%, 1/4W	573584	80031	CR251-4-5P100K	REF		
R13	RES, DEP. CAR, 180 +/-5%, 1/4W	573048	80031	CR251-4-5P180E	1		
R14	RES, VAR, 500 +/-20%, 1/2W	226068	02111	62-1-1-501	1		
R15	RES, DEP. CAR, 200 +/-5%, 1/4W	573055	80031	CR251-4-5P200E	REF		
R16	RES, DEP. CAR, 680 +/-5%, 1/4W	573154	80031	CR251-4-5P680	1		
R17	RES, DEP. CAR, 100K +/-5%, 1/4W	573584	80031	CR251-4-5P100K	REF		
R18	RES, DEP. CAR, 100 +/-5%, 1/4W	573014	80031	CR251-4-5P100E	6		
R19	RES, DEP. CAR, 100 +/-5%, 1/4W	573014	80031	CR251-4-5P100E	REF		
R20	RES, DEP. CAR, 100 +/-5%, 1/4W	573014	80031	CR251-4-5P100E	REF		
R21	RES, MTL. FILM, 499 +/-1%, 1/8W	289256	91637	CMF554490F	2		
R22	RES, MTL. FILM, 499 +/-1%, 1/8W	289256	91637	CMF554490F	REF		

Table 5-5. A4 Magnetic Tape PCB Assembly (cont)

REF DES	DESCRIPTION	FLUKE STOCK NO.	MFG SPLY CODE	MFG PART NO.	TOT QTY	REC QTY	N O T E
R23	RES, MTL. FILM, 100K +/-1%, 1/8W	248807	91637	CMF551003F	1		
R24	RES, MTL. FILM, 100K +/-1%, 1/8W	248807	91637	CMF551003F	REF		
R26	RES, DEP. CAR, 2K +/-5%, 1/4W	573238	80031	CR251-4-5P2K	2		
R27	RES, DEP. CAR, 100K +/-5%, 1/4W	573584	80031	CR251-4-5P100K	REF		
R28	RES, DEP. CAR, 100K +/-5%, 1/4W	573584	80031	CR251-4-5P100K	REF		
R29	RES, MTL. FILM, 40.2K +/-1%, 1/8W	235333	91637	CMF554022F	1		
R30	RES, MTL. FILM, 200K +/-1%, 1/8W	261701	91637	CMF552003F	1		
R31	RES, DEP. CAR, 27K +/-5%, 1/4W	573477	80031	CR251-4-5P27K	1		
R32	RES, DEP. CAR, 2K +/-5%, 1/4W	573238	80031	CR251-4-5P2K	REF		
R33	RES, DEP. CAR, 100K +/-5%, 1/4W	573584	80031	CR251-4-5P100K	REF		
R34	RES, DEP. CAR, 100K +/-5%, 1/4W	573584	80031	CR251-4-5P100K	REF		
R35	RES, MTL. FILM, 10K +/-1%, 1/8W	168260	91637	CMF551002F	2		
R36	RES, MTL. FILM, 10K +/-1%, 1/8W	168260	91637	CMF551002F	REF		
R37	RES, DEP. CAR, 20K +/-2%, 1/4W	573444	80031	CR251-4-2P20K	1		
R38	RES, DEP. CAR, 100 +/-5%, 1/4W	573014	80031	CR251-4-5P100E	REF		
R39	RES, DEP. CAR, 100 +/-5%, 1/4W	573014	80031	CR251-4-5P100E	REF		
R40	RES, DEP. CAR, 100K +/-5%, 1/4W	573584	80031	CR251-4-5P100K	REF		
R41	RES, DEP. CAR, 1.8K +/-5%, 1/4W	573220	80031	CR251-4-5P1K8	1		
R42	RES, DEP. CAR, 10K +/-5%, 1/4W	573394	80031	CR251-4-5P10K	REF		
R43	RES, DEP. CAR, 1K +/-5%, 1/4W	573170	80031	CR251-4-5P1K	1		
R44	RES, DEP. CAR, 200 +/-5%, 1/4W	573055	80031	CR251-4-5P200E	REF		
R45	RES, DEP. CAR, 100 +/-5%, 1/4W	573014	80031	CR251-4-5P100E	REF		
R46	RES, DEP. CAR, 10K +/-5%, 1/4W	573394	80031	CR251-4-5P10K	REF		
TP1-4	CONNECTOR, POST	267500	00779	86144-2	REF		
U1②	IC, N-MOS, PERIPHERAL INTERFACE	536094	89536	536094	1	1	
U2	IC, TTL, BUFFERS & INTERFACE GATES	524736	01295	SN74LS38N	2	1	
U3	IC, TTL, BUFFERS & INTERFACE GATES	524736	01295	SN74LS38N	REF		
U4	IC, LIN, ARRAY, QUAD, PNP, XSTR	477828	12040	DH3467CN	1	1	
U5	IC, LIN, OP-AMP	402669	12040	LM324N	1	1	
U6	IC, LIN, DC MOTOR SPEED REGULATOR	536383	89536	536383	1	1	
W1	CABLE, MAGNETIC TAPE (W/J2)	581801	89536	581801	1		
XU1	SOCKET, IC, 40-PIN	429282	09922	DILB40P-108	1		
Y1	CRYSTAL, 6 MHZ, +/-0.015%	461665	89536	461665	1	1	

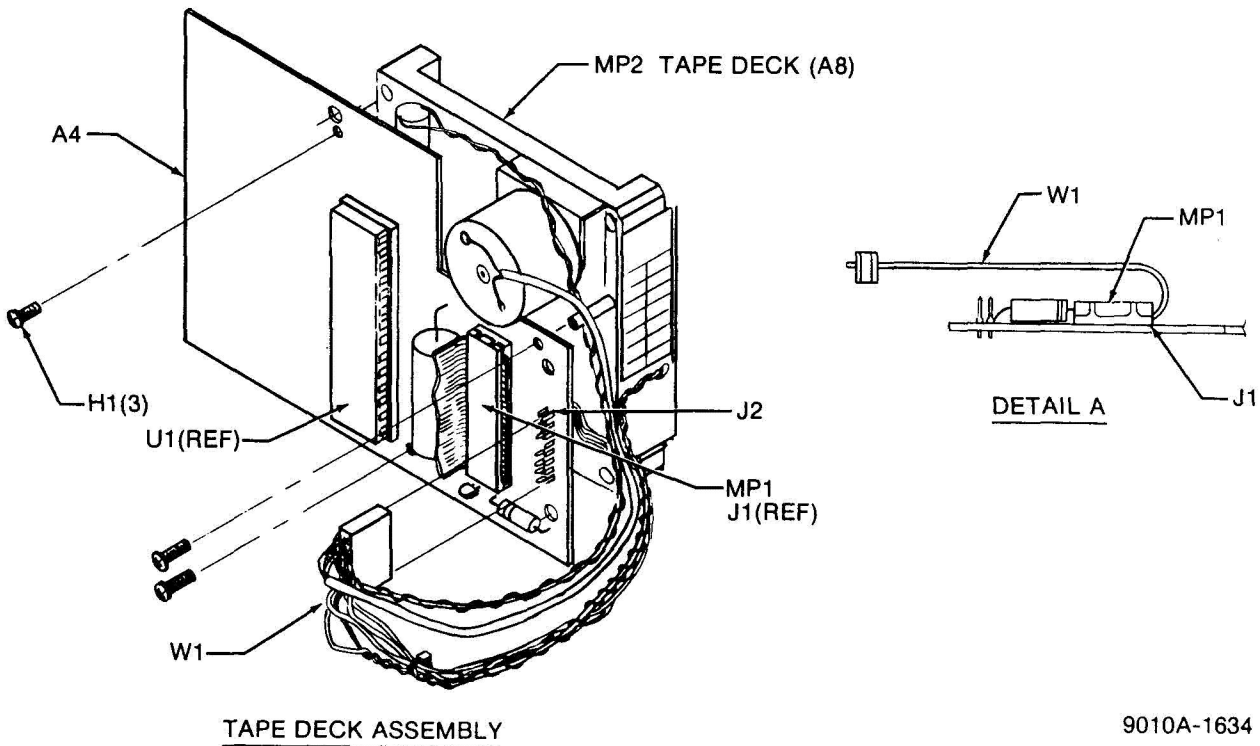
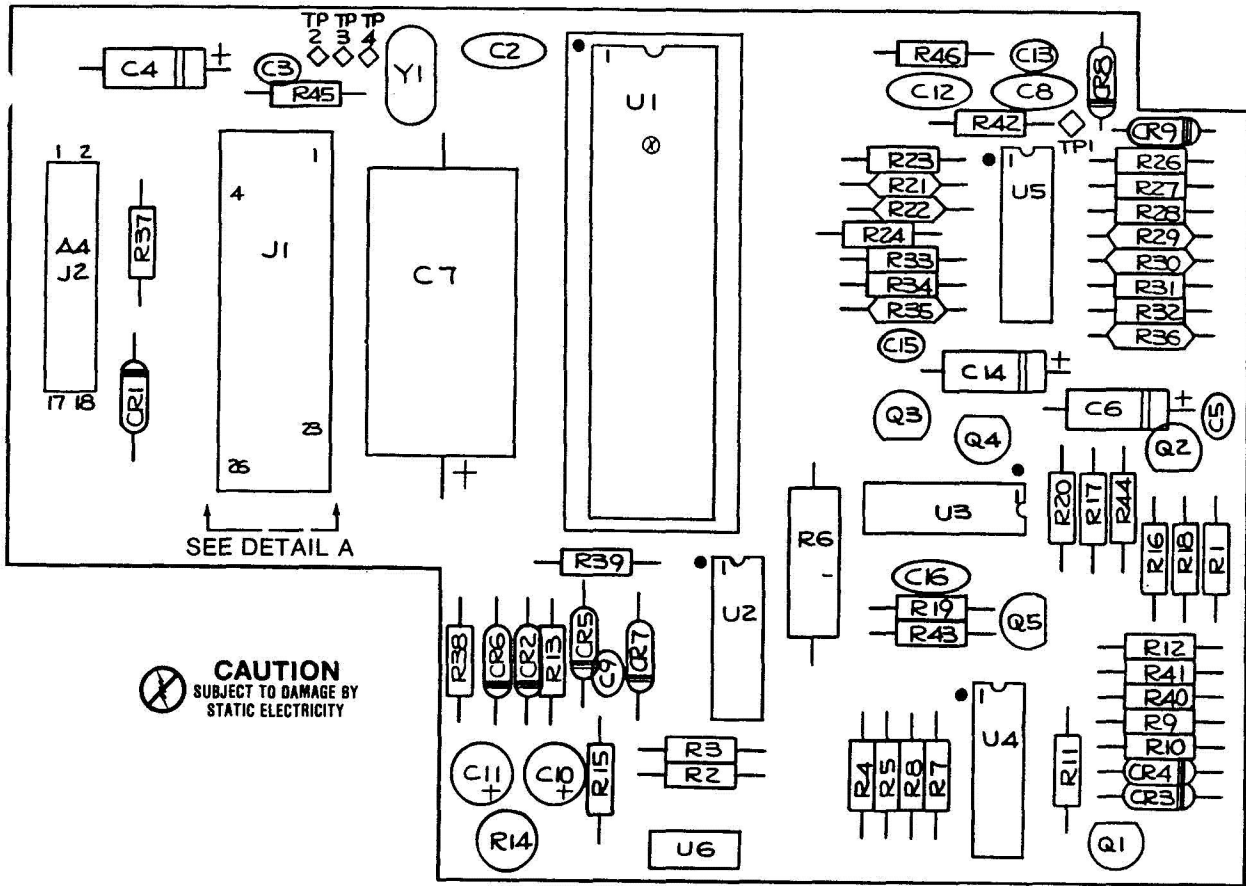

9010A-1634

Figure 5-5. A4 Magnetic Tape PCB Assembly

CHANGE #3

Magnetic Tape Assembly - REV. D1 (15835)

Delete CR8 and CR9 from across R27
 DIODE, MULTI-PELLET/375484/09214/MPD300

Add R25
 RES, VAR, 10K +/-10%,1/2W/285171/89536/285171

Change R23 and R24
 FROM; RES, MTL FLM, 100K +/-1%,1/8W/248807/91637/CMF551003F
 TO: RES, MTL FLM, 49.9K +/-1%,1/8W/268821/91637/CMF554992F

Change R29
 FROM: RES, MTL FLM, 40.2K +/-1%,1/8W/235333/91637/CMF554022F
 TO: RES, DEP CAR, 100K +/-5%,1/4W/573584/80031/CR251-4-5P100K

Change R30
 FROM: RES, MTL FLM, 200K +/-1%,1/8W/261701/91637/CMF552003F
 TO: RES, DEP CAR, 200K +/-5%,1/4W/573634/80031/CR251-4-5P68K

Change R31
 FROM: RES, DEP CAR, 27K +/-5%,1/4W/573477/80031/CR251-4-5P27K
 TO: RES, DEP CAR, 68K +/-5%,1/4W/573550/80031/CR251-4-5P68K

Change R35 and R36
 FROM: RES, MTL FLM, 10K +/-1%,1/8W/168260/91637/CMF551002F
 TO: RES, DEP CAR, 10K +/-5%,1/4W/573394/80031/CR251-4-5P10K

Change C12
 FROM: CAP, CER, 39PF +/-5%,1000V/417410/72982/858-000-R2G0-390J
 TO: CAP, CER, 560PF +/-10%,600V/106203/72982/801-00-X5R0-560K

Change C13
 FROM: CAP, CER, 0.01UF +/-20%,100V/407361/72982/8121-A200-W5R-103M
 TO: CAP, CER, 0.22UF +/-20%,50V/519157/51406/RPE111Z5U224M50V

In addition to noting the above component changes on the schematic diagram, also cross-connect the input ends of R21 and R22 so that the HEAD+ input of A4J2 (also collector of Q4) connects to R22, and the HEAD- input (and collector of Q3) connects to R21.

Magnetic Tape Assembly - REV. D & REV. A2 (15699)

Make REV. D1 changes plus the following change.

Delete C16
 CAP, CER, 0.1UF/368647/71590/UK10-140

CHANGE #4

Magnetic Tape Assembly - REV. A1

Make the changes listed under Change #3 plus the following changes.

Change R37

FROM: RES, DEP CAR, 20K +/-2%,1/4W/573444/80031/CR251-4-2P20K
 TO: RES, DEP CAR, 100K +/-5%,1/4W/573584/80031/CR251-4-5P100K

Change R6

FROM: RES, COMP, 1.2 +/-5%,1/2W/218701/01121/EB1R25
 TO: RES, COMP, 9.1 +/- %,1W/573790/01121/GB9R15

Refer to the following Magnetic Tape Assembly schematic diagram.

Magnetic Tape Assembly - REV. A (15082)

Make the REV. A1 changes plus the following changes.

Change R14

FROM: RES, VAR 500 +/-20%,1/2W/226068/02111/62-1-1-501
 TO: RES, VAR, 500 +/-10%,1/2W/291120/89536/291120

Change R45

FROM: RES, DEP CAR, 100 +/-5%,1/4W/573014/80031/CR251-4-5P100E
 TO: RES, DEP CAR, 10K +/-5%,1/4W/348839/80031/CR251-4-5P10K

Delete TP3 and TP4

Refer to the following Magnetic Tape Assembly schematic diagram.

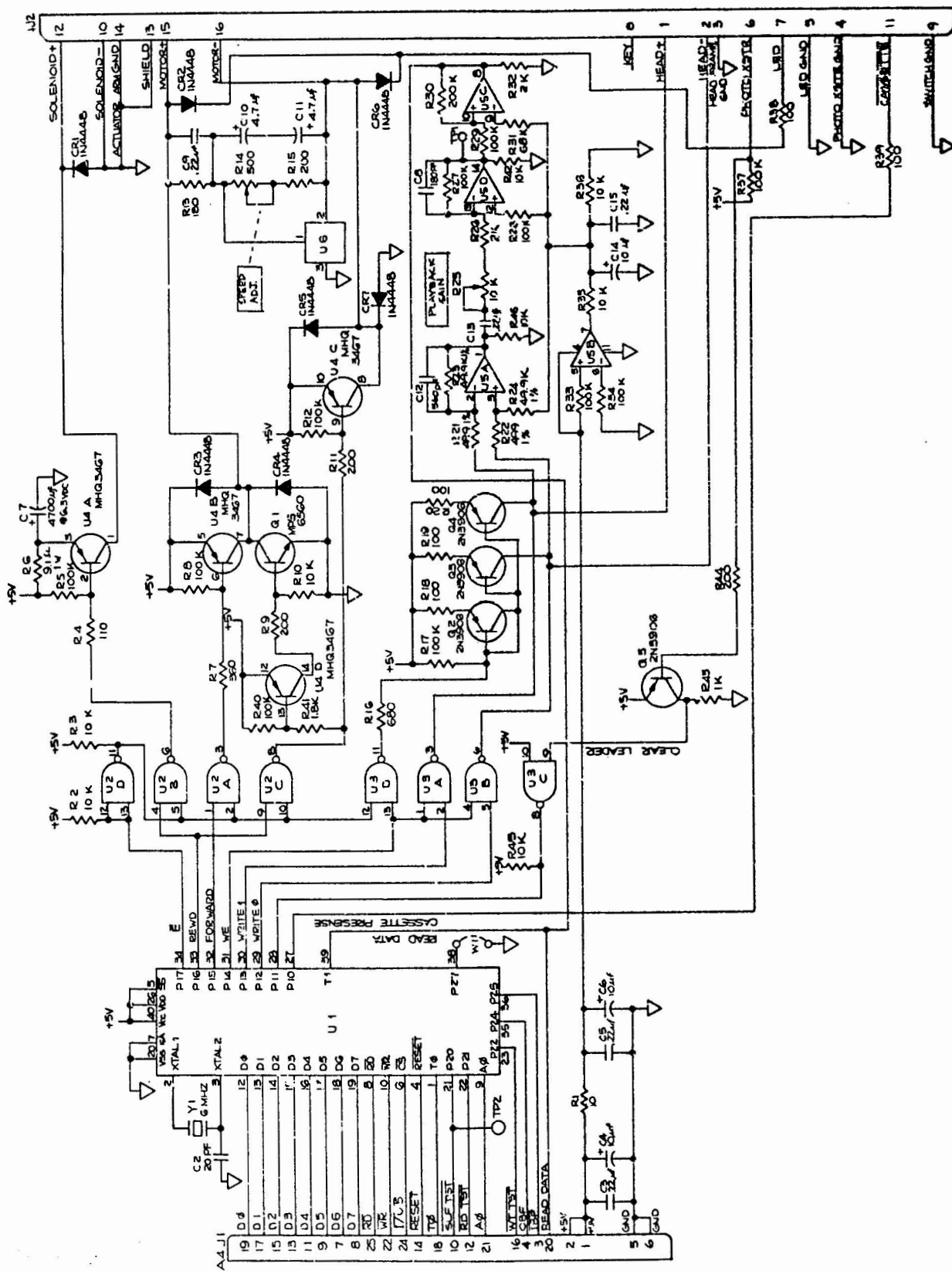

Magnetic Tape Assembly Schematic for Change #4

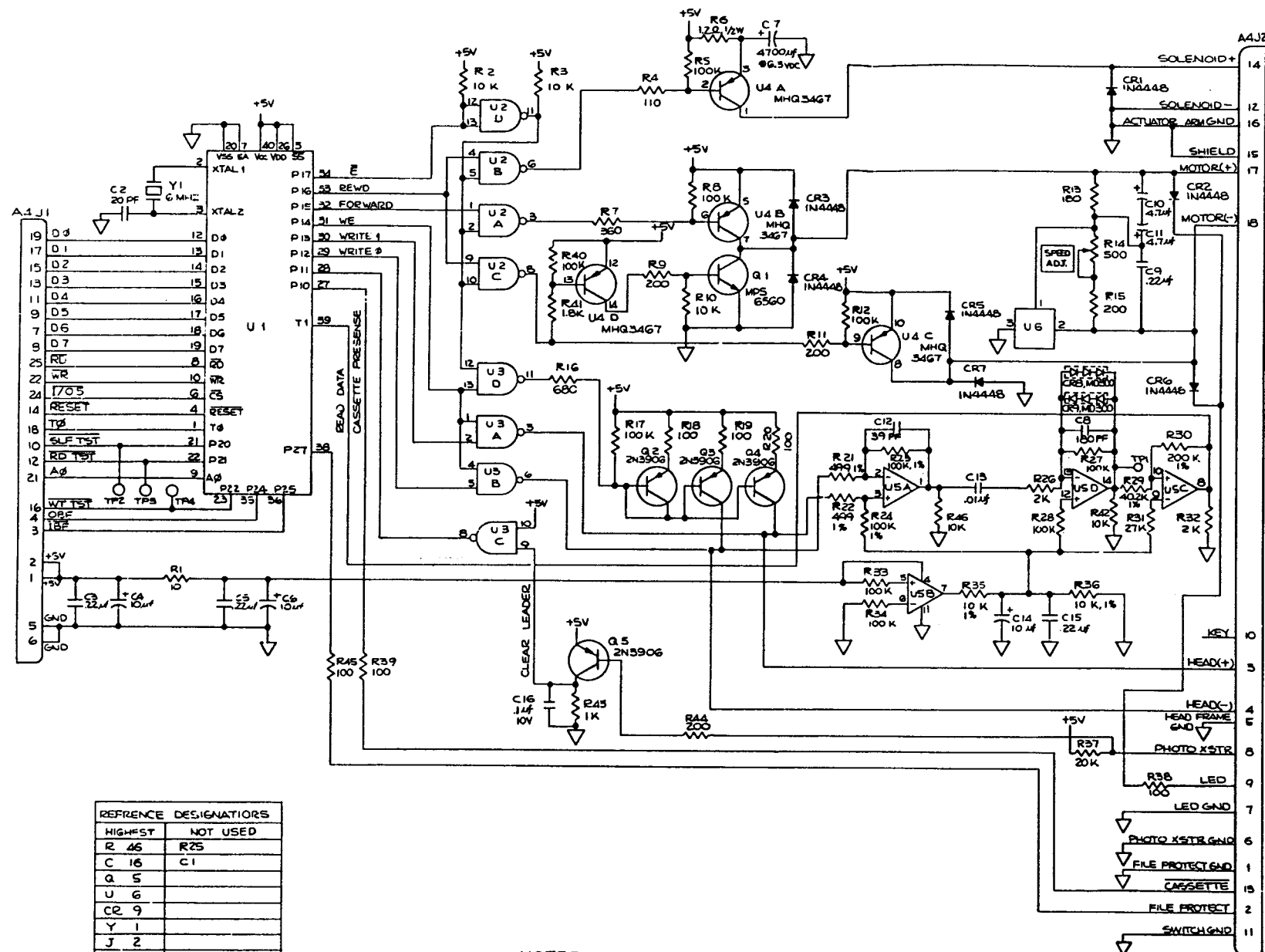

REF	TYPE	+5V	GND	QTY
U1	8041	20	20	1
U2,3	74LS38	14	7	2
U5	LM324	4	11	1
U6	TDA1151	—	3	1
U4	MHQ3467	—	—	—

REFERENCE DESIGNATORS	
HIGHEST	NOT USED
R 46	R25
C 16	C1
Q 5	
U 6	
CR 9	
Y 1	
J 2	

NOTES
 1 UNLESS OTHERWISE SPECIFIED, ALL RESISTORS ARE IN OHMS, 1/4W AND 5%.
 2 ALL CAPACITORS ARE IN MICROFARADS

Figure 8-5. A4 Magnetic Tape PCB Assembly (cont)